

- ① BRASS PER QQ-B-626.
- ② BERYLLIUM COPPER PER ASTM-B-196
- ③ NYLON PER ASTM-D-4066, BLACK
- ④ POLYMETHYLPENTENE GENERAL PURPOSE, NATURAL
- ⑤ 0.00076[.000030] MINIMUM GOLD PER MIL-G-45204.
- ⑥ 0.00254[.000100] MINIMUM GOLD PER MIL-G-45204.
- ⑦ SHIELDED CABLE #26=NAS-702 CLASS A & C, AND MIL-W-16878 TYPES E & EE, SHIELDED CABLE #24=NAS-702 CLASS A & C, AND MIL-W-16878 TYPES E & EE, SHIELDED CABLE #22=NAS-702 CLASS C, AND MIL-W-16878 TYPE E, AND MIL-C-7078A TYPE I NUMBER 1 DIELECTRIC .068 O.D.
- ⑧ RG-174/U, RG-179A/U, RG-187/U, AND 21-598.
- ⑨ SHIELDED CABLE #26=NAS-702 CLASS A, AND MIL-C-7078A TYPE II.
- 1 O. SEE IS 408-1770
- ⑩① NYLON PER ASTM-D-4066, NATURAL

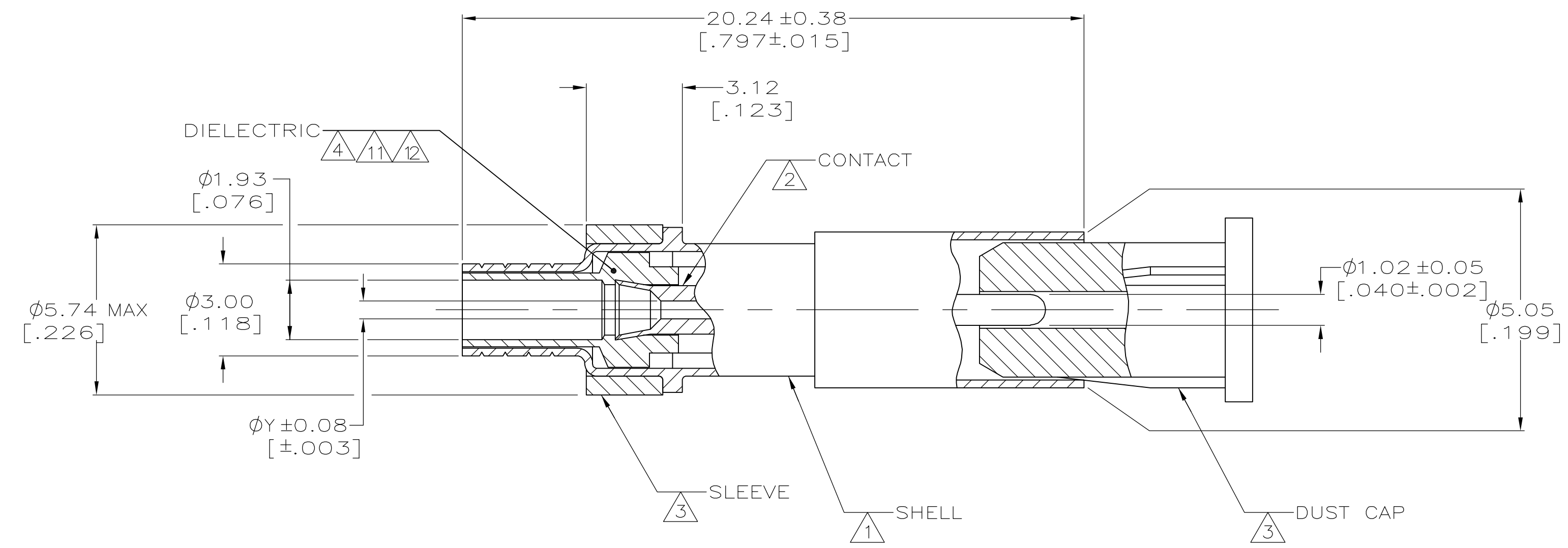

OBSOLETE	⑤	⑤	.034 OUNCES	-	-	0.81[.032]	-	-	-	1-201144-8
	-	-	1.65 GRAMS MAX	⑧	45368-2	-	328666	201142-2	201144-1	1-201144-1
OBSOLETE	⑥	⑥	.034 OUNCES	-	-	0.81[.032]	-	-	-	201144-7
	⑤	⑤	.034 OUNCES	-	-	0.81[.032]	-	-	-	201144-6
	⑤	⑤	.034 OUNCES	-	-	1.07[.042]	-	-	-	201144-5
	⑤	⑤	.034 OUNCES	-	-	0.58[.023]	-	-	-	201144-3
	⑤	⑤	.034 OUNCES	-	-	0.58[.023]	-	-	-	201144-1
CONTACT PLATING	SHELL PLATING	WEIGHT	CABLE OR WIRE SIZE	CRIMP TOOL	Y	③ FERRULE QTY=1	② SPRING RETENTION QTY=1	① SOCKET ASSY QTY=1	PART NUMBER	

THIS DRAWING IS A CONTROLLED DOCUMENT.

DIMENSIONS: mm [INCHES]	TOLERANCES UNLESS OTHERWISE SPECIFIED:	DWN J. LIPPERT 18 DEC 89	tyco Electronics	Tyco Electronics Corporation Harrisburg, Pa 17105-3608
0 PLC ± -	1 PLC ± -	CHK M. SNEED 22 FEB 90	APRD B. ADAMS 22 FEB 90	NAME
2 PLC ± -	3 PLC ± 0.20[.008]	PRODUCT SPEC 108-12021		
4 PLC ± -	ANGLES ± -	APPLICATION SPEC		
MATERIAL	FINISH	SIZE	CAGE CODE	DRAWING NO
		A1	00779	201144
CUSTOMER DRAWINGS		SCALE	SHEET	REV
		8:1	1 OF 1	AV